



## How to Solve the Backbone Connection Dilemma



**steve ulrich - consulting systems engineer**  
**21-oct, 2008**

“I have nothing to offer but blood, toil, tears and sweat...” -- Winston Churchill

## The Future ... Visual Networking

### Today

- Video primarily used for entertainment
- Video quality on the internet is still poor
- Voice/Data communications can't replicate in-person experience
- Video stuck on a single device

### Visual Networking

- Video is widely used across entertainment, communications, and information applications
- Internet video is Hi-Def
- In-person experiences possible over the network
- Video is available on device of choice
- Community based discovery augments search. Content is easier to find.



## The Impact of Video



## Three Waves of Internet Video Growth

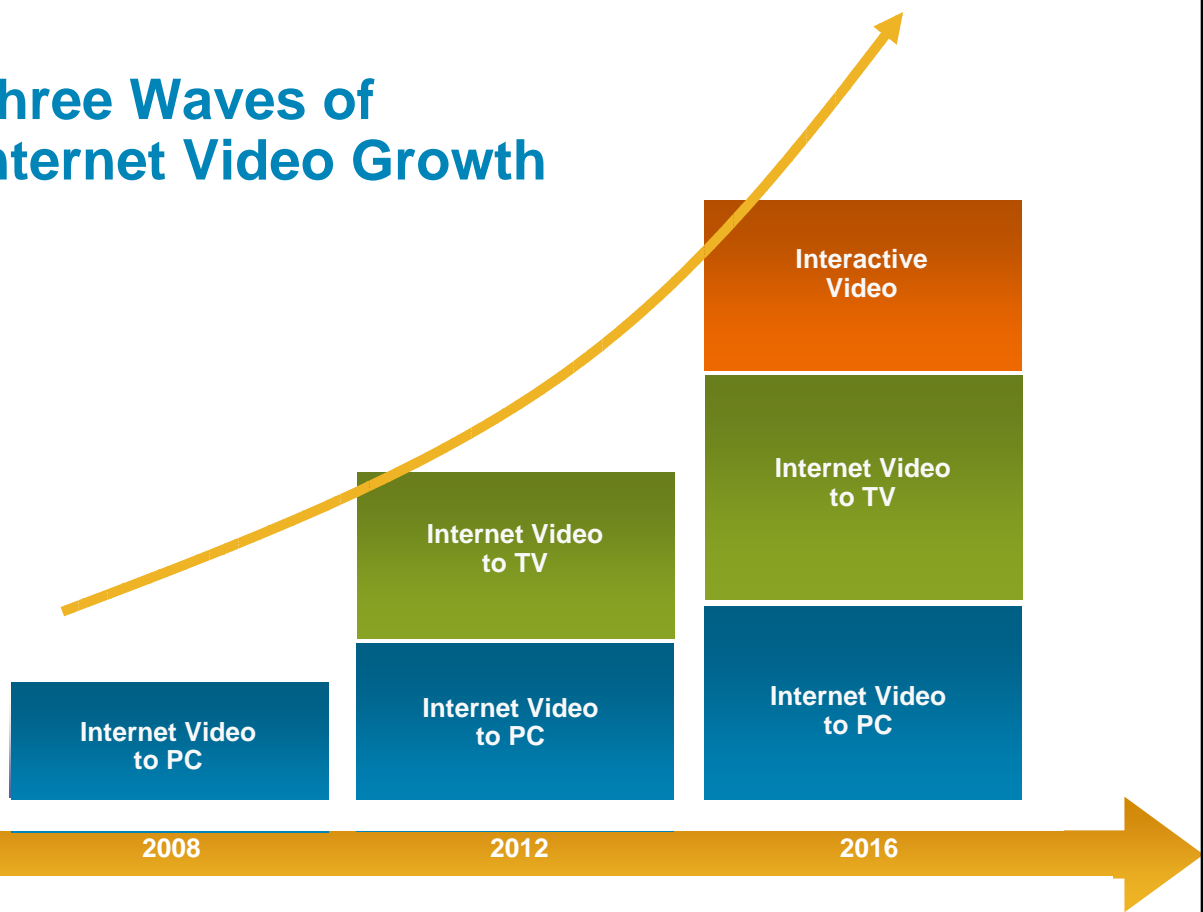

Source: Cisco, 2008

# Three Waves of Internet Video Growth

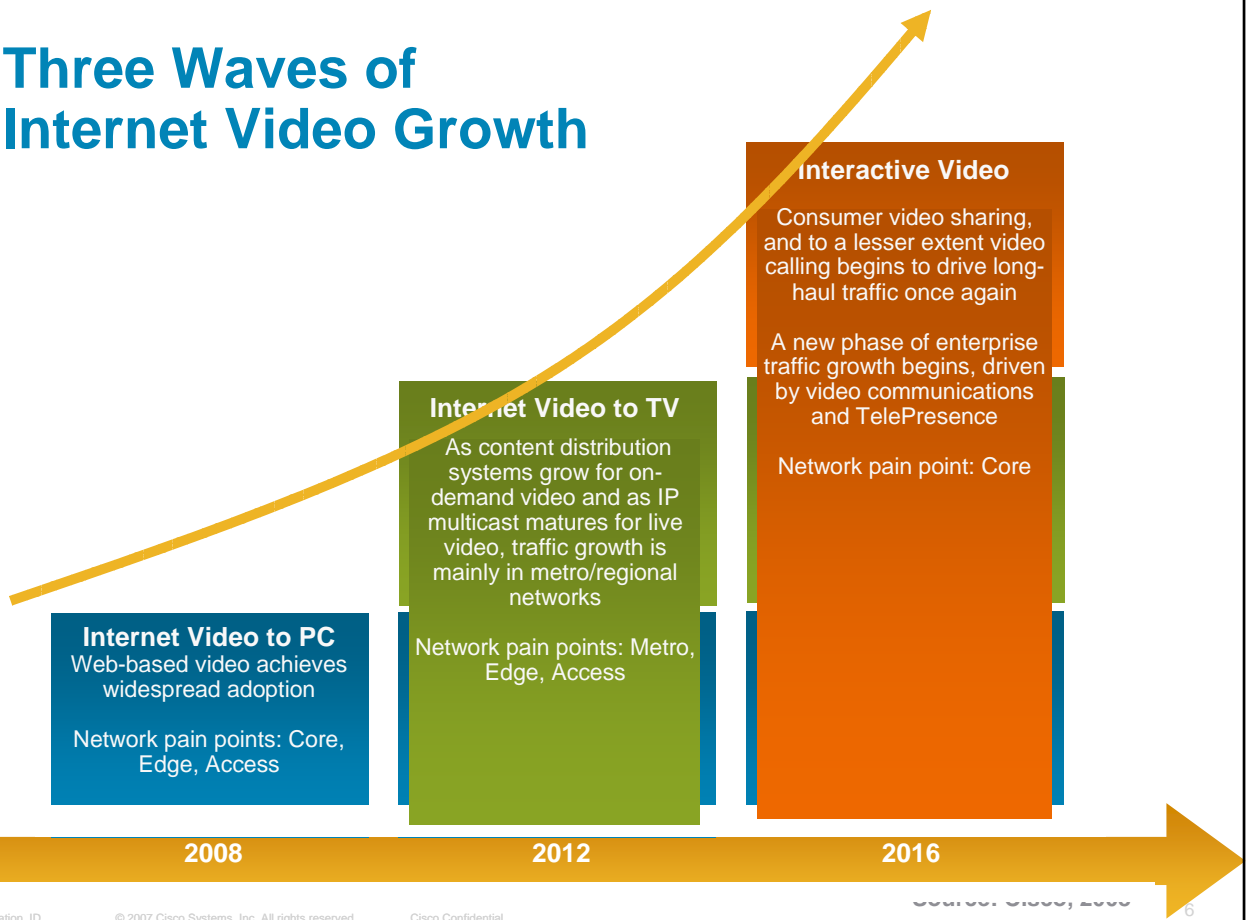

# Global Consumer Internet Traffic Mix

Video will be nearly 50% of traffic by 2012

43% CAGR 2007-2012

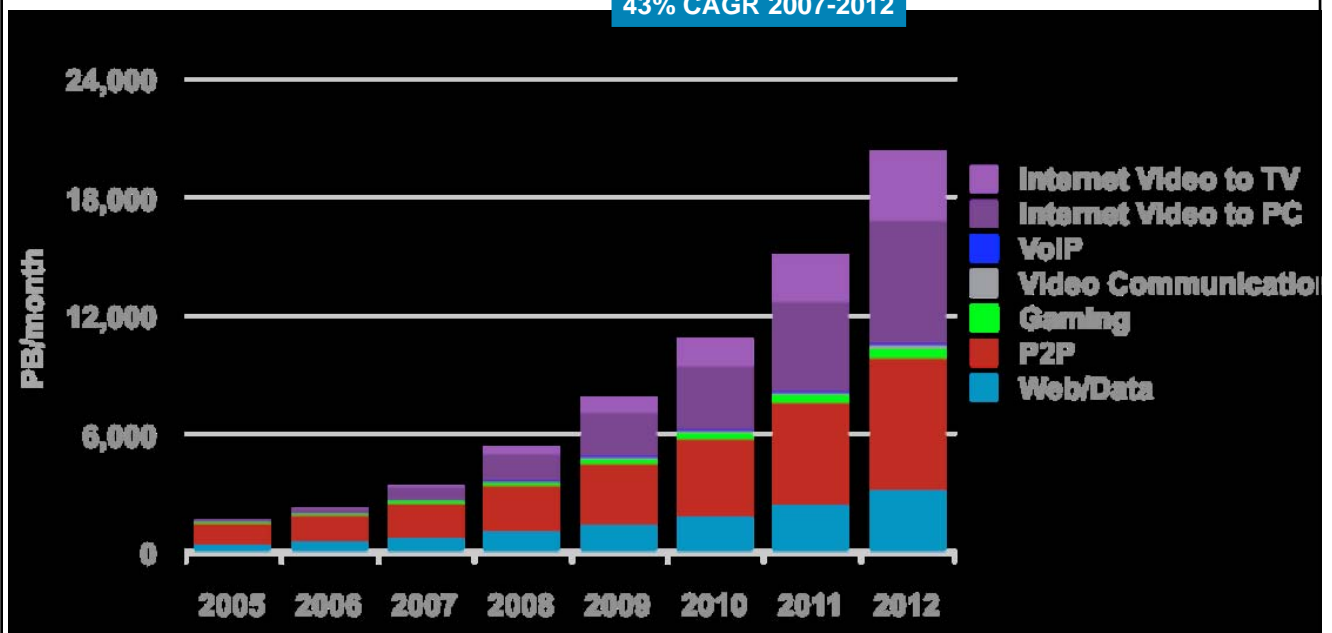

Source: Cisco analysis of multiple sources, 2008

# Global Consumer Internet Traffic Mix

Video will be nearly 50% of traffic by 2012

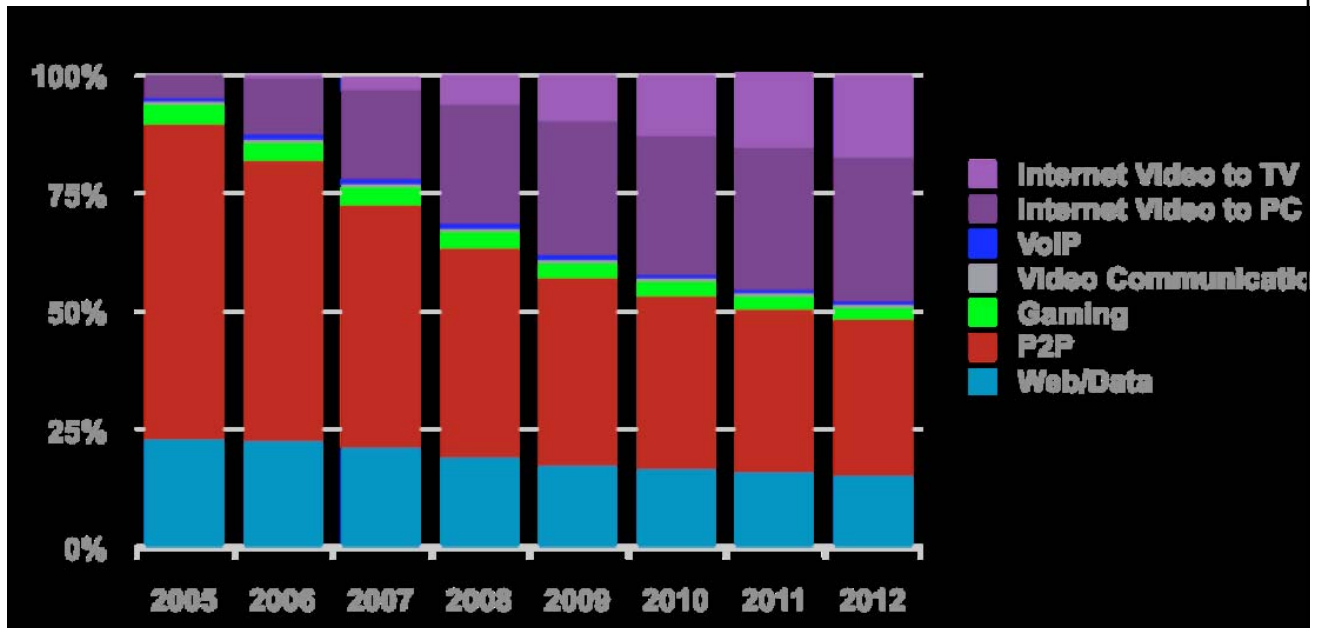

Source: Cisco analysis of multiple sources, 2008

© 2007 Cisco Systems, Inc. All rights reserved. Cisco Confidential

## Without Video, Consumer IP Doubles by 2012 With Video, Consumer IP Quadruples by 2012

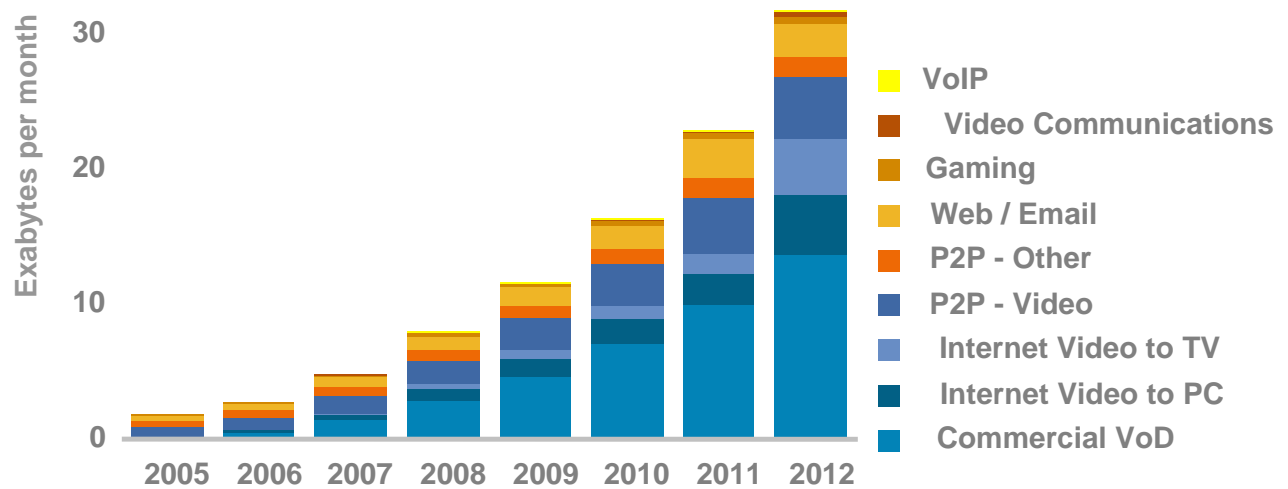

**Video to reach 87% of Consumer IP in 2012**

Source: Cisco Visual Networking Index – Forecast, 2007-2012

Presentation ID: © 2007 Cisco Systems, Inc. All rights reserved. Cisco Confidential

## what to do?

- enforce per-subscriber fairness and tier service offering
  - tiered service pricing changes behaviors
  - subscribers pay for their share of network impact
- coop-etition
  - consortiums and co-ops purchasing common transport infrastructure and upstream BB connectivity
  - peer locally whenever possible - offload local traffic - don't go to a tier 1 city / POP if you don't have to
- lay more fiber - only optical provides the capacity required to address next-generation of

## Traffic Optimization – P2P Control

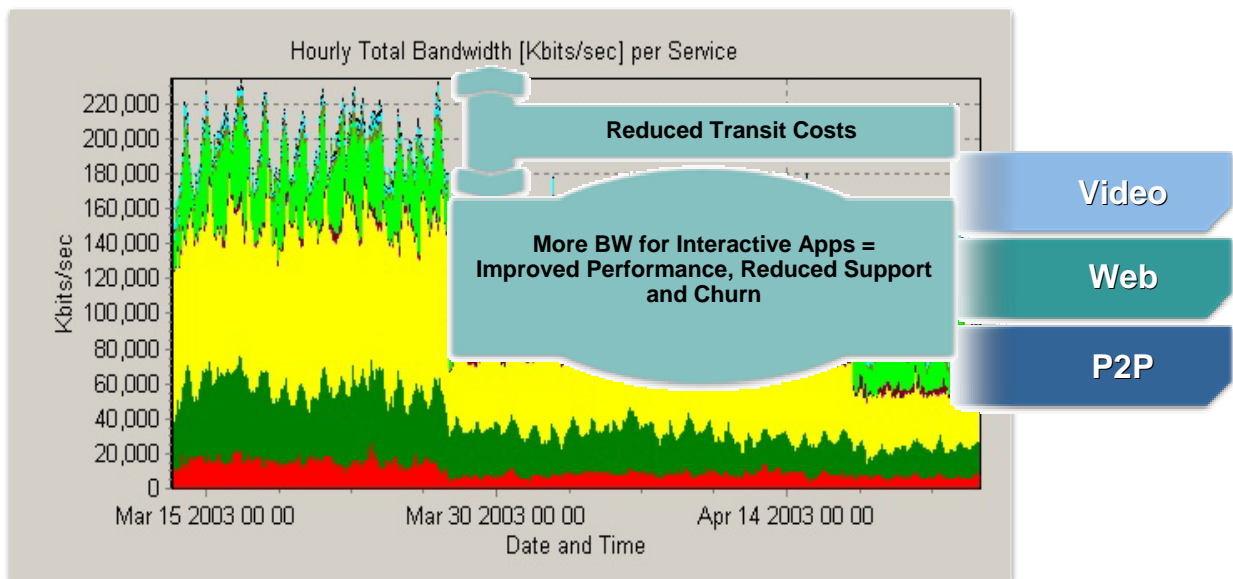

- Savings on network OPEX and CAPEX

# DPI Case Study – Telephone company

- Background

IOC/RLEC in West Texas

Currently offers DSL to the residential customers and transport service to local ISP's

Growing number of customers (currently 2-3K, future 6-10K)

- Problem

SP seeks to provide tiered services by applications solution to its customers

SP needs to control P2P traffic to protect network bandwidth from congestion on the user level as well globally

SP needs protect customers from denial of service attacks and provide other security features

- Solution

DPI platform allows SP to identify, classify, guarantee performance and deliver tiered services based on each unique application

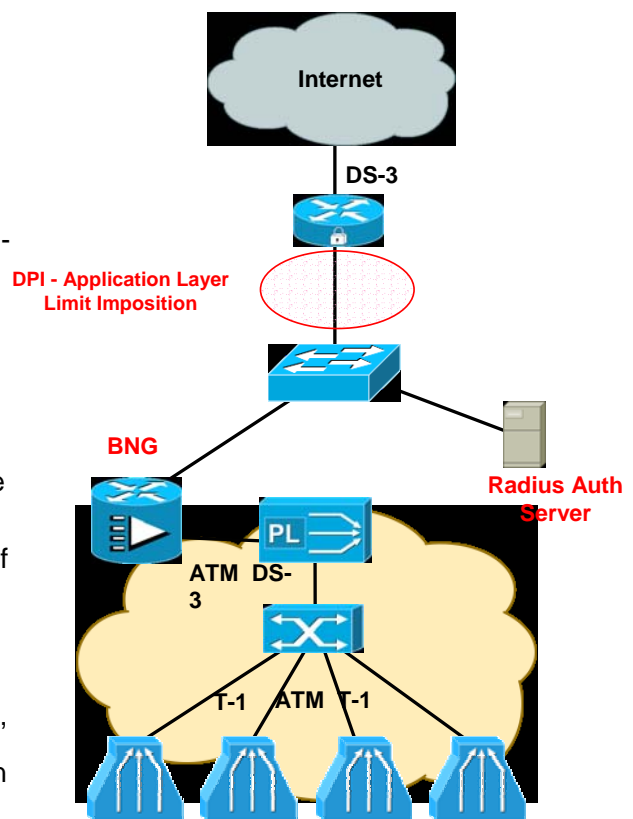

## consortiums / coops / local NAPs

- numerous RLEC customers pooling transport resources and working cooperatively to offload traffic, purchase connectivity to national BB providers
- engage rural oriented SPs
  - there are a number of providers focusing on the rural markets - TDS, Windstream, Norlight, et al.
- Create a local NAP/IXP
  - peer with neighboring providers and offload local traffic
  - <http://www.pch.net> - packet clearing house - lots of good information on creating your own IXP

## Ethernet & DWDM improving transport economics

- next generation transport direction is clear ... Ethernet
- cheaper router interfaces, cheaper backhaul, flexibility in operation, etc.
- long term investment direction should be oriented around Ethernet
- DWDM provides a compelling (and often the only) means of increasing capacity to rural markets

## conclusion

- Internet traffic growth doesn't show any signs of decreasing
- video will impact the shape of the growth curve
- Internet video to the television is increasingly common and will drive different user behaviors
- techniques to tactically manage BB traffic growth exist, and will play a key role in helping SPs manage growth
- there are no easy answers to increasing backbone capacity and reach for rural providers
- investment and upgrade of transport infrastructure should be oriented towards optimal delivery of IP based services